

Re-use tanks and fluff collectors



W555H
Base with removable lint compartment

Features and benefits

- Tanks for the re-use of water or solvent – for lower utility costs
- The re-use tanks are integrated in the base – space saving
- Fluff collectors prevent the drainpipe from becoming clogged
- Base with removable lint compartment in the front of the machine for easy cleaning and maintenance

FLUFF COLLECTORS

988918010: W555H
 988918021: W465H, W565H, W475H/NS, W575H/N/S
 988918022: W4105H/N/S, W5105H/N/S, W4130H/N/S, W5130H/N/S
 988703041: W4180H/N/S, W5180H/N/S, W4240H, W5240H, W4250N/S, W5250N/S, W4300H/N/S, W5300H/N/S

Material: Stainless steel.
 Feature: Filter for easy cleaning.
 Drain connection: \varnothing 32 mm (25 l)
 \varnothing 50 mm (45 l, 75 l)

	A	B	L
25 l	280	165	615
45 l	345	220	680
75 l	480	215	820
100 l	485	220	930

W555H
 C = 155 mm
 D = 95 mm (E=200)
 D = 165 mm (E=290)



988918016: W555H
 Material: Stainless steel.
 Feature: Filter for easy cleaning.
 The collector can be connected to the base frame of W555H on any side or rear of the machine. Including cover and hoses.

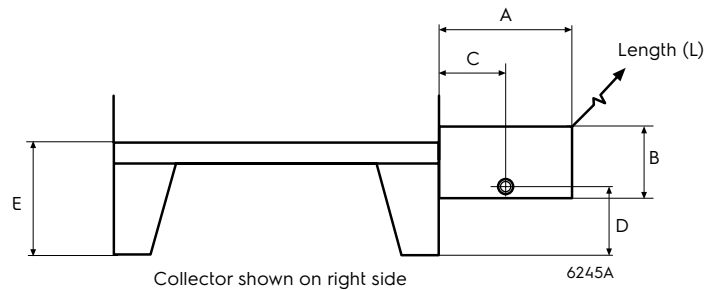

BASE; with removable fluff compartment



988918360: W555H
 988918515: W465H, W565H, W475H, W575H
 Material: Stainless steel.
 Feature: Lintbox integrated.
 Easy to clean under the base.
 Depth: W555H: 650 mm
 W465H, W565H: 700 mm
 W475H, W575H: 700 mm

988918514: W465H, W565H,
 W475H/N/S, W575H/N/S,
 988918524: W4105H/N/S, W5105H/N/S
 Material: Galvanised, grey painted steel
 with stainless steel lint compartment
 Content: 33 litres.
 Drain connection: \varnothing 50 mm
 Depth: 910 mm

	W555H	W465H, W565H	W475H, W575H
A	110	180.5	180.5
B	220	340	340

A	B	C	D	E	F
700	470	185	300	60	20-50

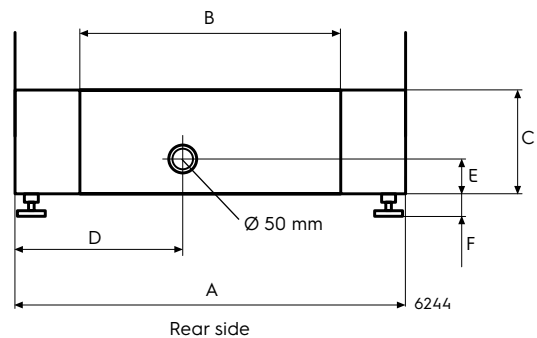
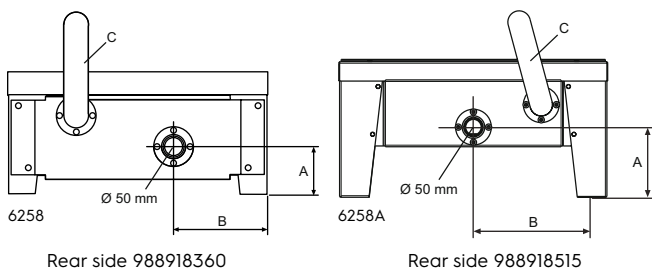
C = Drain from machine

TANKS; for re-use of water or solvent

988803825 (50Hz): W465H, W475S,
 W4105H/S,
 W4130H/S
 988803818 (50Hz): W4180H/N/S, W4240H,
 W4250S, W4330S
 988803826 (60Hz): W465H, W475S,
 W4105H/S,
 W4130H/S
 988803819 (50Hz): W4180H/S, W4240H,
 W4250S, W4330S

A = Drain valve box only:

988803823 (50Hz): W465H, W475S,
 W4105H/S,
 W4130H/S,
 W4180H/S, W4240H,
 W4250S, W4330S
 988803824 (60Hz): W465H, W475S,
 W4105H/S,
 W4130H/S,
 W4180H/S, W4240H,
 W4250S, W4330N/S

Material: Stainless steel
 Feature: For re-use of water/solvent.
 Including pump, filter, valves,
 hose and wire harness for
 connection to the machine.
 Content: 140 or 200 litres



BASE; with integrated tank

- 988918717 (50Hz): W4130H
- 988918817 (50Hz): W4180H
- 988918957 (50Hz): W4240H
- 988919017 (50Hz): W4300H
- 988918718 (60Hz): W4130H
- 988918818 (60Hz): W4180H
- 988918958 (60Hz): W4240H
- 988919018 (60Hz): W4300H

Material: Galvanised steel with a stainless steel tank and front panel.

Feature: For re-use of water/solvent
Including pump, filter, valves, hose and wire harness for connection to the machine.

Content: 120 litres: W4130H
145 litres: W4180H
160 litres: W4240H, W4300H

A	B	C	D	E	F	G	H	I
900	570	300	300	380	500	170	430	75
960	600	300	330	380	530	170	460	75
1010	630	300	350	380	560	170	490	75
1010	630	300	350	380	560	170	490	75

- K Drain \varnothing 75 from machine to drain
- L Drain \varnothing 75 from overflowed tank to drain
- M Cold water connection, DN20
- N Connection for cleaning tank

